

# PIAGGIO VESPA GTS 125/300 '07- '22

## M O U N T I N G I N S T R U C T I O N S

REF 20501

GTS TOURING WINDSHIELD

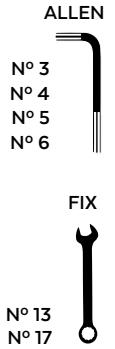

ID.	PIEZA/PART	DESCRIPCIÓN	DESCRIPTION	QTY.	REF.:
1		Cúpula TOURING	TOURING screen	1	10796W/HM3
2		Soporte Izquierdo superior	Upperleft support	1	SOPOR4P6UL20501
3		Soporte derecho superior	Upper right support	1	SOPOR4P6UR20501
4		Soporte Izquierdo inferior	Lower left support	1	SOPOR4P6LL20501
5		Soporte derecho inferior	Lower right support	1	SOPOR4P6LR20501
6		Arandela Grower M6 DIN 127 ( negra)	M6 DIN127 washer (black)	2	ARAND-D127--528
7		Arandela M6 DIN125 (negra)	M6 DIN125 washer (black)	2	ARANDEPD125-054
8		Casquillo Ø10xØ14 x28mm	Ø10xØ14x28mm Arrowhead	2	CASQUI-----738
9		Tornillo M8x45 DIN912 (Rosca Izquierda)	M8x45 DIN912 screw (Left thread)	1	TORNI-D912-871
10		Tornillo M8x45 DIN912 (Rosca derecha)	M8x45 DIN912 screw (Right thread)	1	TORNI-AD912-508
11		Tuerca autoblocante M8 (Rosca Izquierda)	M8 locknut (Left thread)	1	TUERCA-----809
12		Tuerca autoblocante M8 (Rosca derecha)	M8 locknut (Right thread)	1	TUEA-D985.8-M8-
13		Tornillo M6x65 DIN912	M6x65 DIN 912 screw	2	TORNI-D912-474
14		Cilindro Roscado	Threaded Cylinder	2	CASQUI-2P---873
15		Cilindro Pasante	Through Cylinder	2	CASQUI-2P---873
16		Silentblock Ø9xØ6x8mm	Ø9xØ6x8mm silentblock	4	AROPASACABLES-3
17		Casquillo con valona Ø12xØ6,8x7,3	Ø12xØ6,8x7,3 bush with flange	4	CASQUI-1A---750
18		Tornillo allen M5x16 Ø11 ISO 7380	M5x16 Ø11 ISO 7380 allen screw	4	TORNI-I7380-493
19		Tapón tornillo M5 ISO 7380	M5 ISO 7380 screw cap	4	TAPON-----85
20		Arandela Grower M8 DIN127 ( negra)	M8 DIN127 Grower washer	2	ARAND-G8----505
21		Arandela M8 DIN125 ( negra)	M8 DIN125 washer (black)	2	ARANDPD125A-018
22		Tapón tuerca M8	M8 nut cap	2	CAPERUTM8--21/2
23		Tapón M8 DIN 912	M8 DIN912 screw cap	2	TAPA--CHC1145OE

# PIAGGIO VESPA GTS 125/300 '07-'22

INSTRUCCIONES DE MONTAJE - MOUNTING INSTRUCTIONS - MONTAGEANLEITUNG

**1**

DISASSEMBLY  
DESMONTAJE

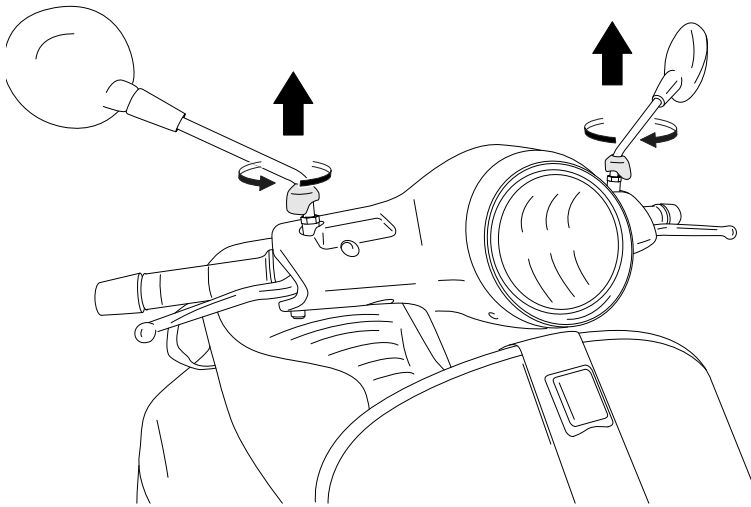

**2**

ASSEMBLY  
MONTAJE

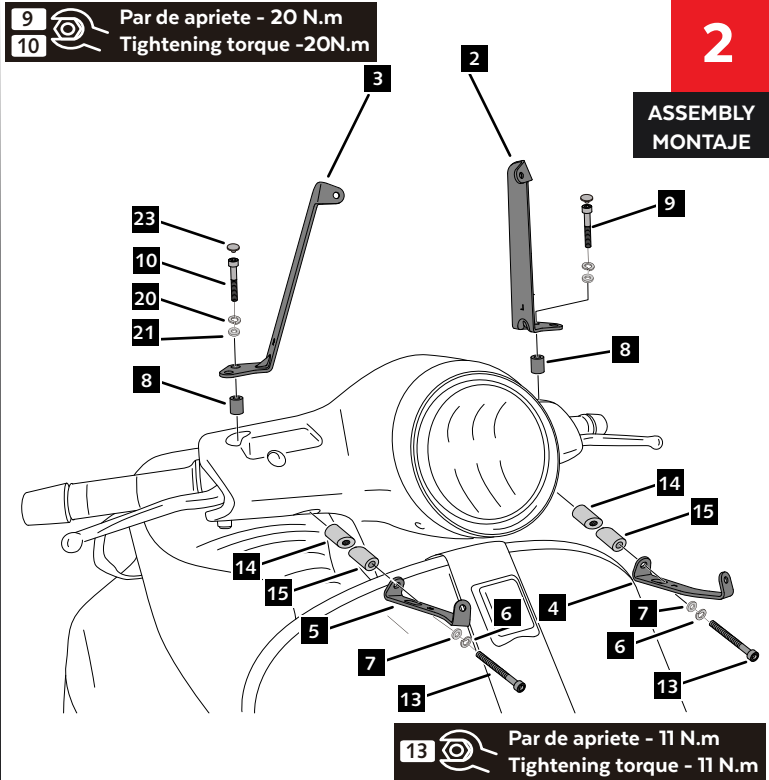

**3**

ASSEMBLY  
MONTAJE

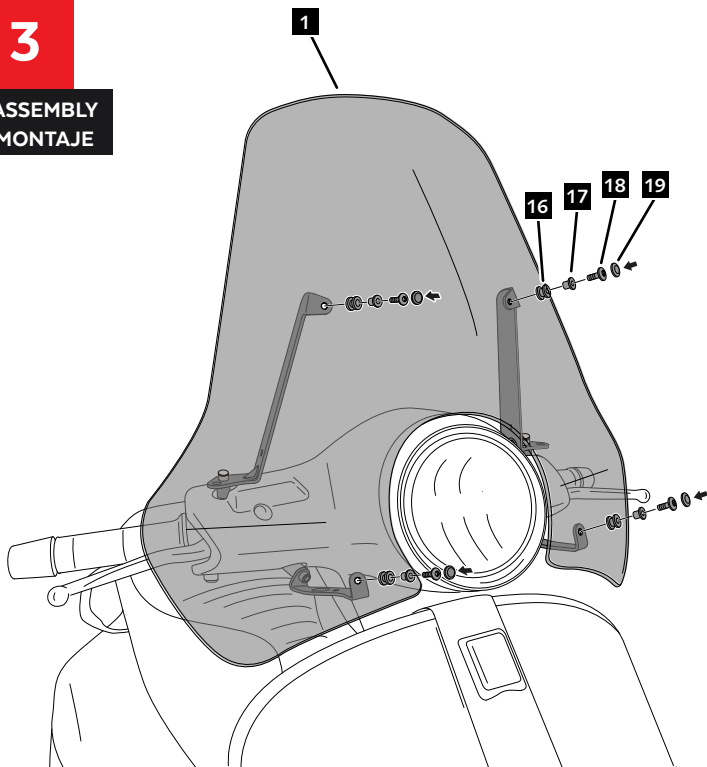

**4**

ASSEMBLY  
MONTAJE

