

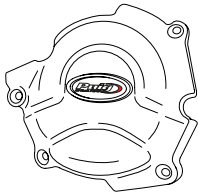

SUZUKI GSX 8S - GSX 8R '23

REF 21663N

TAPAS LATERAL IZQUIERDO / LEFT SIDE COVERS



ID.	PIEZA / PART	DESCRIPCIÓN	DESCRIPTION	QTY.	REF.:
1		Tapa izquierda	Left cover	1	PT.S07.1
2		Tornillo M6x40 DIN912	M6x40 DIN912 screw	2	--
3		Tornillo M6x55 DIN912	M6x55 DIN912 screw	2	--

RECOMENDAMOS MONTAR LOS TORNILLOS APRETANDO UNIFORMEMENTE UNO TRAS OTRO, PARA APRETAR FINALMENTE CON DINAMOMÉTRICA
WE RECOMMEND TO MOUNT THE SCREWS UNIFORMLY TIGHTENING ONE AFTER THE OTHER, TO FINALLY TIGHTEN WITH DYNAMOMETRIC

SUZUKI GSX 8S - GSX 8R '23

REF 21663N

INSTRUCCIONES DE MONTAJE - MOUNTING INSTRUCTIONS - MONTAGEANLEITUNG

1

ASSEMBLY
MONTAJE

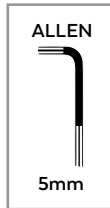

2-3  10,00 N/m - Par de apriete
7,50 lb/ft - Tightening torque

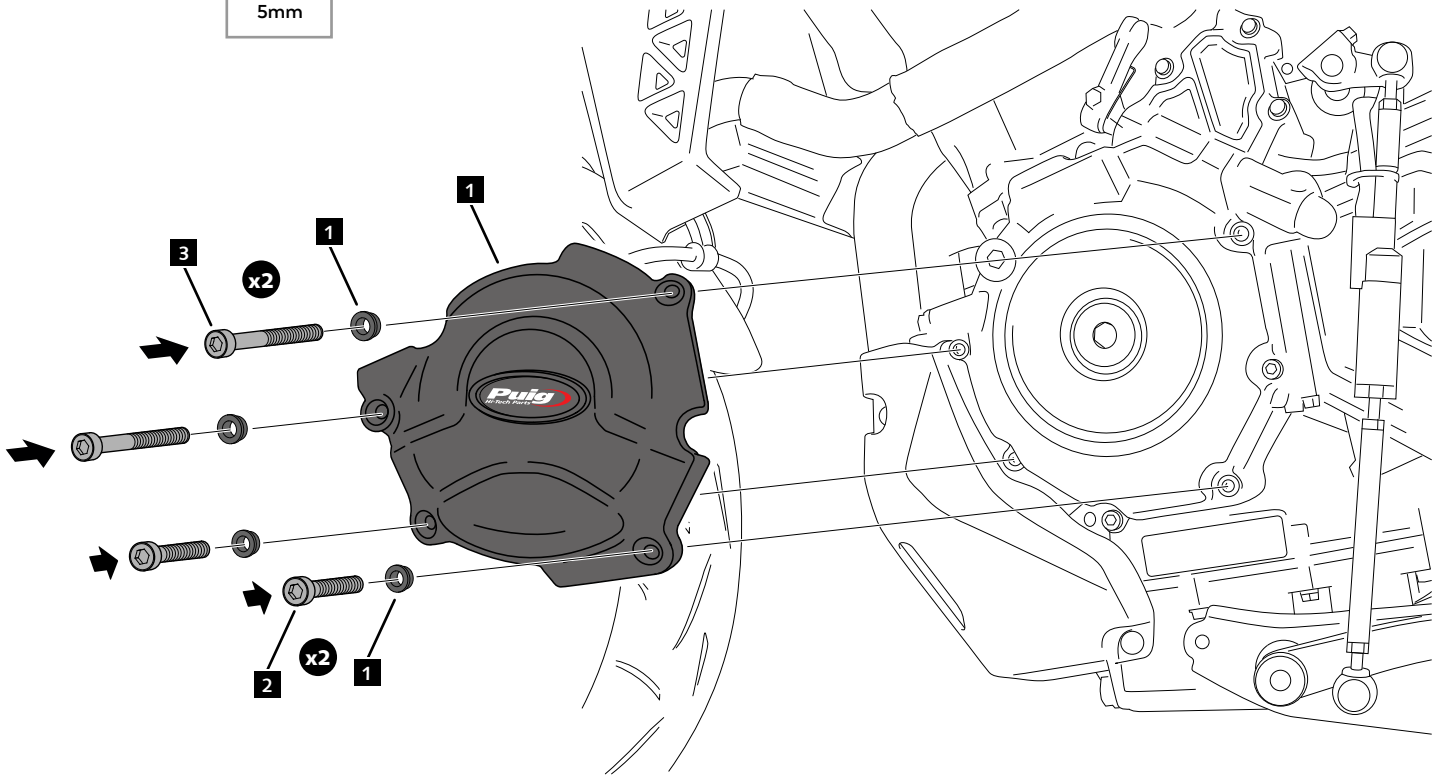

**CONSULTAR EN NUESTRA PAGINA WEB LA DISPONIBILIDAD DEL VIDEO DE MONTAJE DE ESTA REFERENCIA.
CONSULT OUR WEBSITE THE VIDEO MOUNT AVAILABILITY OF THIS REFERENCE.**



SUZUKI GSX 8S - GSX 8R '23

REF 21663N

TAPAS LATERAL DERECHO / RIGHT SIDE COVERS



1 Person



30 min



EASY



ID.	PIEZA / PART	DESCRIPCIÓN	DESCRIPTION	QTY.	REF.:
1		Tapa derecha 1	Right cover 1	1	PT.S07.3
2		Tapa derecha 2	Right cover 2	1	PT.S07.2
3		Tornillo M6x35 DIN912	M6x35 DIN912 screw	5	-
4		Tornillo M6x50 DIN912	M6x50 DIN912 screw	3	-

RECOMENDAMOS MONTAR LOS TORNILLOS APRETANDO UNIFORMEMENTE UNO TRAS OTRO, PARA APRETAR FINALMENTE CON DINAMOMÉTRICA
WE RECOMMEND TO MOUNT THE SCREWS UNIFORMLY TIGHTENING ONE AFTER THE OTHER, TO FINALLY TIGHTEN WITH DYNAMOMETRIC

SUZUKI GSX 8S - GSX 8R '23

REF 21663N

INSTRUCCIONES DE MONTAJE - MOUNTING INSTRUCTIONS - MONTAGEANLEITUNG

1

ASSEMBLY
MONTAJE

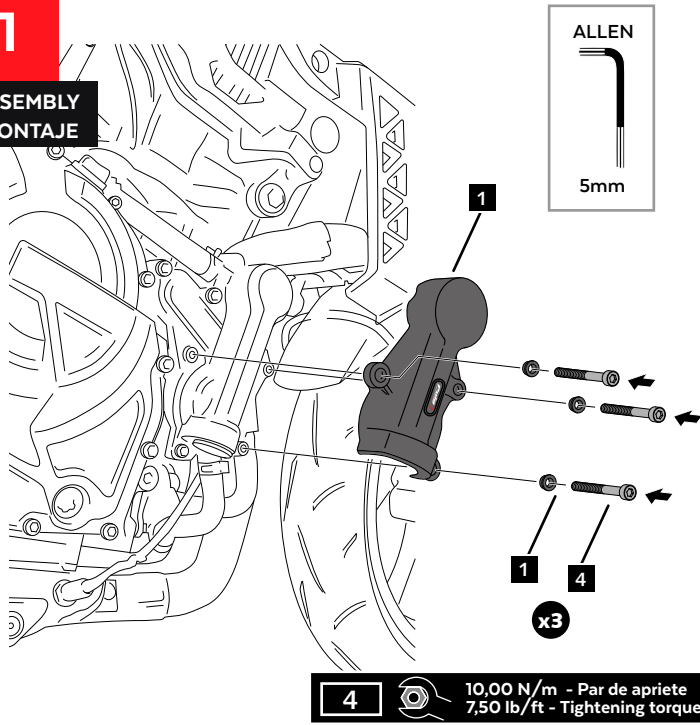

2

DISASSEMBLY
DESMONTAJE

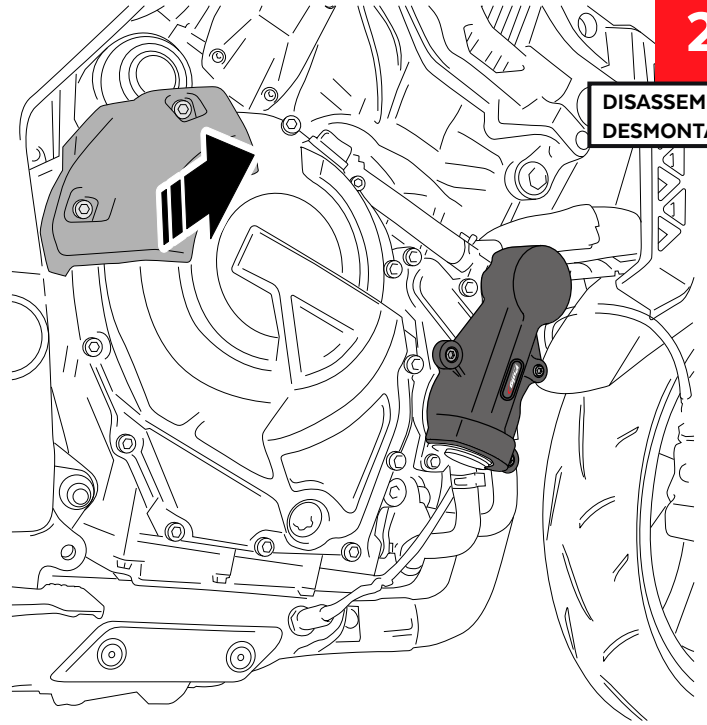

3

ASSEMBLY
MONTAJE

