

KTM 890 SMT '23-

M O U N T I N G I N S T R U C T I O N S

REF 21869

TOURING SCREEN - CÚPULA TOURING

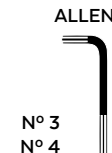

ID.	PIEZA/PART	DESCRIPCIÓN	DESCRIPTION	QTY.	REF.:
1		Cupula Touring	Touring screen	1	11001H/F/WM3
2		Soporte Inferior	Lower support	1	SOPOR3P3-I21868
3		Soporte superior derecho	Right upper support	1	SOPOR3P3SD21868
4		Soporte superior izquierdo	Left upper support	1	SOPOR3P3SI21868
5		Tornillo allen M5x16 Ø11 ISO 7380	M5x16 Ø11 ISO 7380 allen screw	2	TORNI-I7380-493
6		Tapón tornillo M6 ISO 7380	M6 ISO 7380 screw cap	2	TAPON-----86
7		Tornillo allen M6x20 Ø14 ISO 7380	M6x20 Ø14 ISO 7380 allen screw	2	TORNI-I7380-404
8		Casquillo Ø8,5xØ13x3,5	Ø8,5xØ13x3,5 arrowhead	2	CASQUI-----775
9		Tapón tornillo M5 ISO 7380	M5 ISO 7380 screw cap	6	TAPON-----85
10		Tornillo allen M5x12 Ø11 ISO 7380	M5x12 Ø11 ISO 7380 allen screw	4	TORNI-AI----520
11		Arandela de nylon M5	M5 nylon washer	2	ARNV00000000245
12		Arandela de goma Ø4,5xØ11x2mm	Ø4,5xØ11x2mm rubber washer	2	ARAND-EPDM--722
13		Silentblock Ø12xØ6x9	Ø12xØ6x9 silentblock	2	AROPASACABLES-3
14		Casquillo con valona Ø12xØ6,8x7,3	Ø12xØ6,8x7,3 bush with flange	2	CASQUI-1A---750
15		Espuma protectora (12x50mm)	Protection foam (12x50mm)	4	ESPUM-NC+ADHM--
16		Kit adhesivo	Stickers set	1	ADHESI----21868

KTM 890 SMT '23-

INSTRUCCIONES DE MONTAJE - MOUNTING INSTRUCTIONS - MONTAGEANLEITUNG

1

DISASSEMBLY
DESMONTAJE

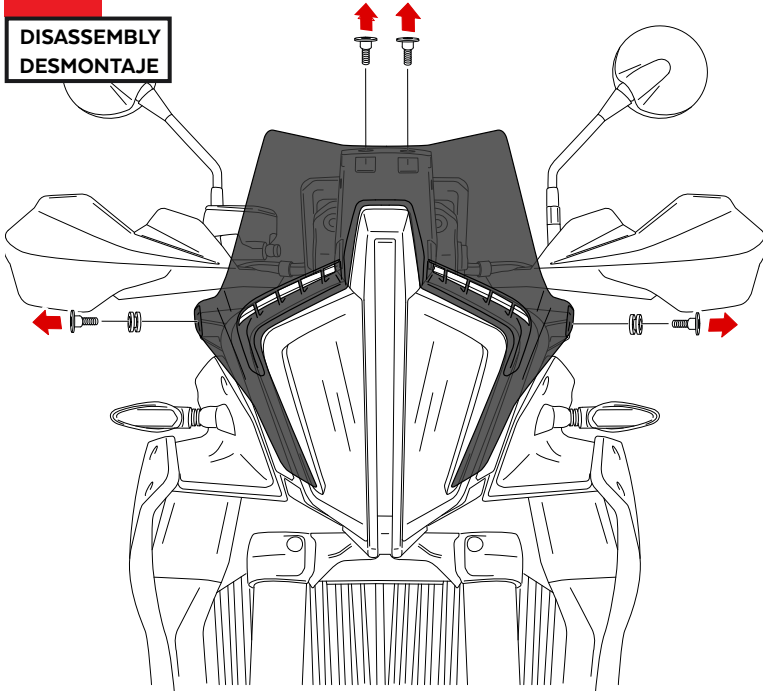

2

DISASSEMBLY
DESMONTAJE

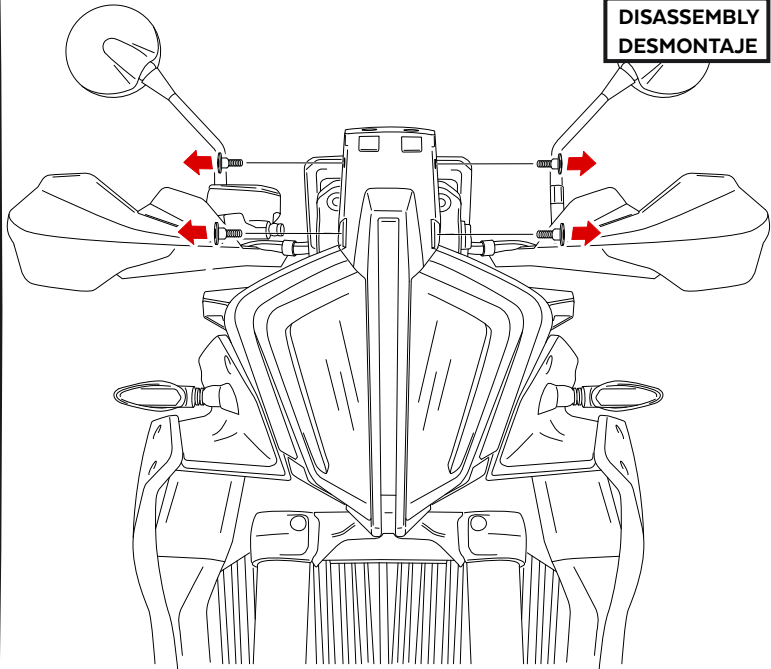

3

ASSEMBLY
MONTAJE

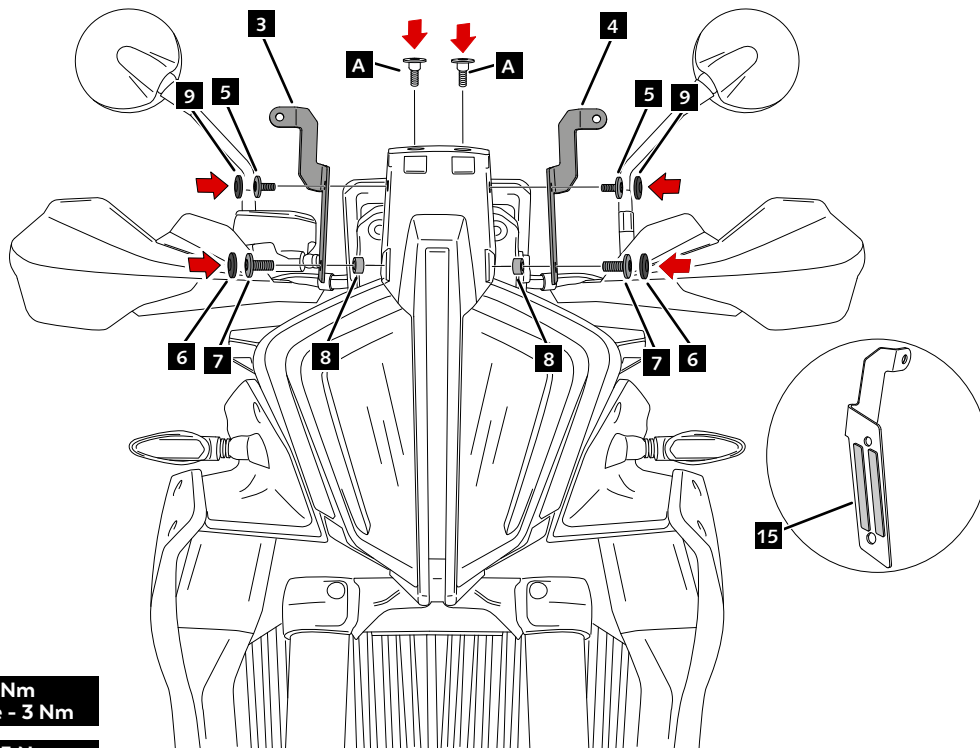

5 Par de apriete - 3 Nm
Tightening torque - 3 Nm

7 Par de apriete - 3.5 Nm
Tightening torque - 3.5 Nm

A Tornillería original
Original screws

KTM 890 SMT '23-

INSTRUCCIONES DE MONTAJE - MOUNTING INSTRUCTIONS - MONTAGEANLEITUNG

4

DISASSEMBLY
DESMONTAJE

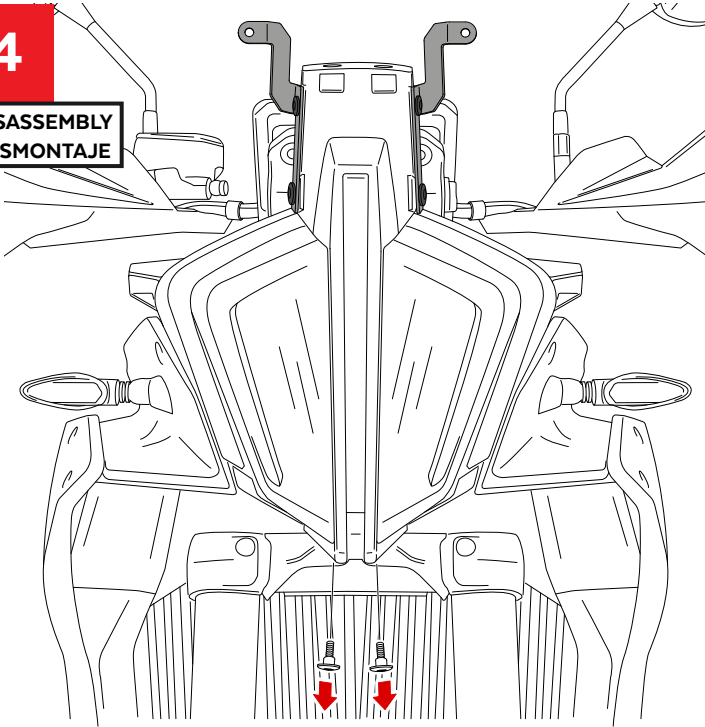

5

ASSEMBLY
MONTAJE

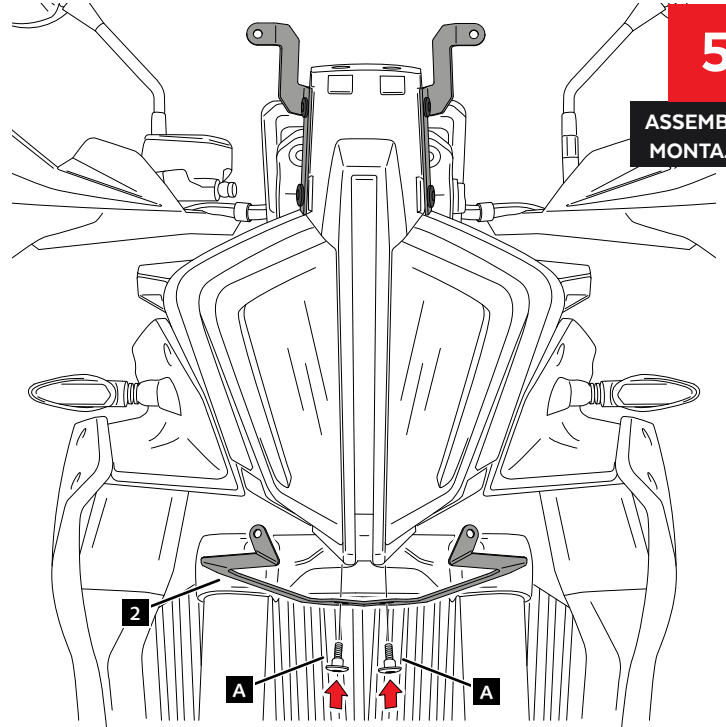

A Tornillería original
Original screws

A Par de apriete - 3.5 Nm
Tightening torque - 3.5 Nm

6

ASSEMBLY
MONTAJE

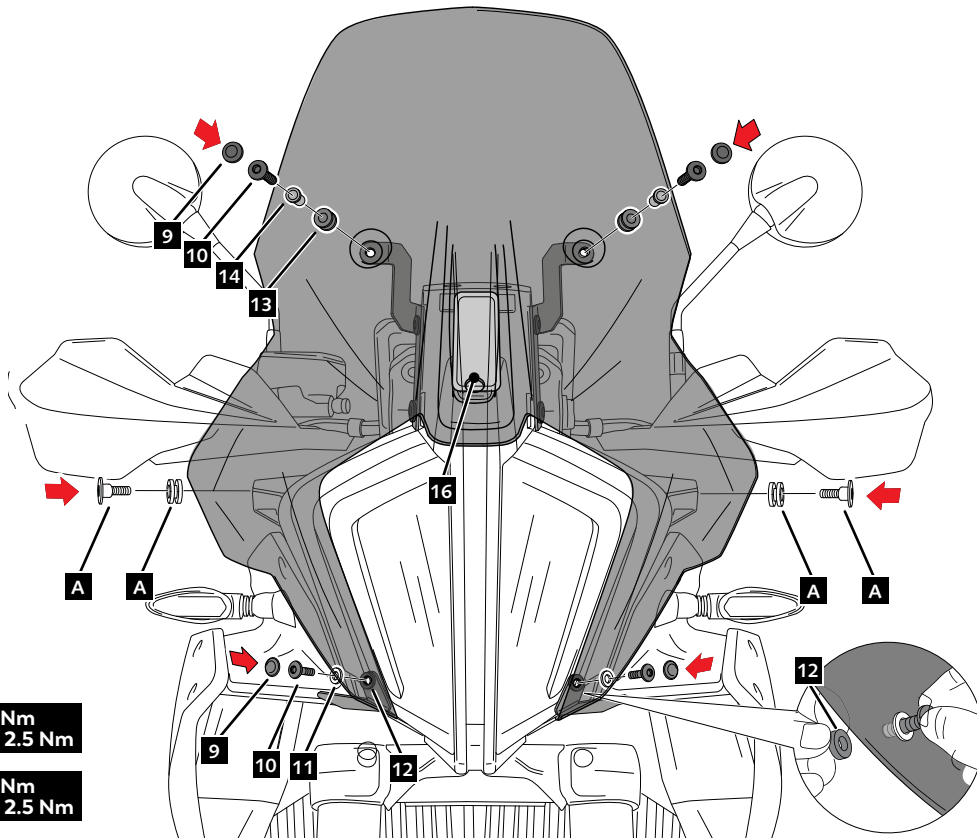

10 Par de apriete - 2.5 Nm
Tightening torque - 2.5 Nm

A Par de apriete - 2.5 Nm
Tightening torque - 2.5 Nm

A Tornillería original
Original screws