

KTM 890 SMT '23-

M O U N T I N G I N S T R U C T I O N S

REF 21869

TOURING SCREEN - CÚPULA TOURING

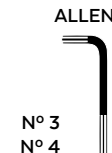

ID.	PIEZA/PART	DESCRIPCIÓN	DESCRIPTION	QTY.	REF.:
1		Cupula Touring	Touring screen	1	11001H/F/WM3
2		Soporte Inferior	Lower support	1	SOPOR3P3-I21868
3		Soporte superior derecho	Right upper support	1	SOPOR3P3SD21868
4		Soporte superior izquierdo	Left upper support	1	SOPOR3P3SI21868
5		Tornillo allen M5x16 Ø11 ISO 7380	M5x16 Ø11 ISO 7380 allen screw	2	TORNI-I7380-493
6		Tapón tornillo M6 ISO 7380	M6 ISO 7380 screw cap	2	TAPON-----86
7		Tornillo allen M6x20 Ø14 ISO 7380	M6x20 Ø14 ISO 7380 allen screw	2	TORNI-I7380-404
8		Casquillo Ø8,5xØ13x3,5	Ø8,5xØ13x3,5 arrowhead	2	CASQUI-----775
9		Tapón tornillo M5 ISO 7380	M5 ISO 7380 screw cap	6	TAPON-----85
10		Tornillo allen M5x12 Ø11 ISO 7380	M5x12 Ø11 ISO 7380 allen screw	4	TORNI-AI----520
11		Arandela de nylon M5	M5 nylon washer	2	ARNV00000000245
12		Arandela de goma Ø4,5xØ11x2mm	Ø4,5xØ11x2mm rubber washer	2	ARAND-EPDM--722
13		Silentblock Ø12xØ6x9	Ø12xØ6x9 silentblock	2	AROPASACABLES-3
14		Casquillo con valona Ø12xØ6,8x7,3	Ø12xØ6,8x7,3 bush with flange	2	CASQUI-1A---750
15		Espuma protectora (12x50mm)	Protection foam (12x50mm)	4	ESPUM-NC+ADHM--
16		Kit adhesivo	Stickers set	1	ADHESI----21868

KTM 890 SMT '23-

INSTRUCCIONES DE MONTAJE - MOUNTING INSTRUCTIONS - MONTAGEANLEITUNG

1

DISASSEMBLY
DESMONTAJE

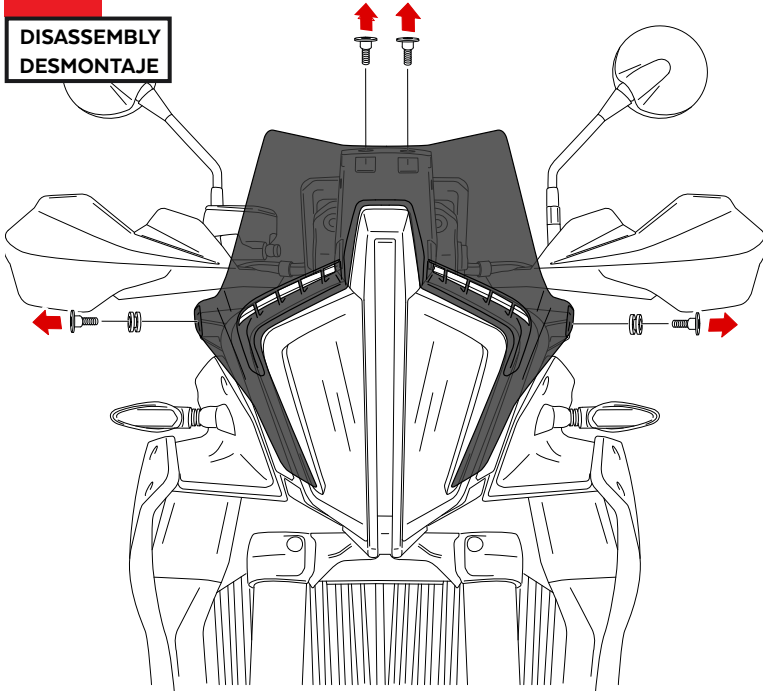

2

DISASSEMBLY
DESMONTAJE

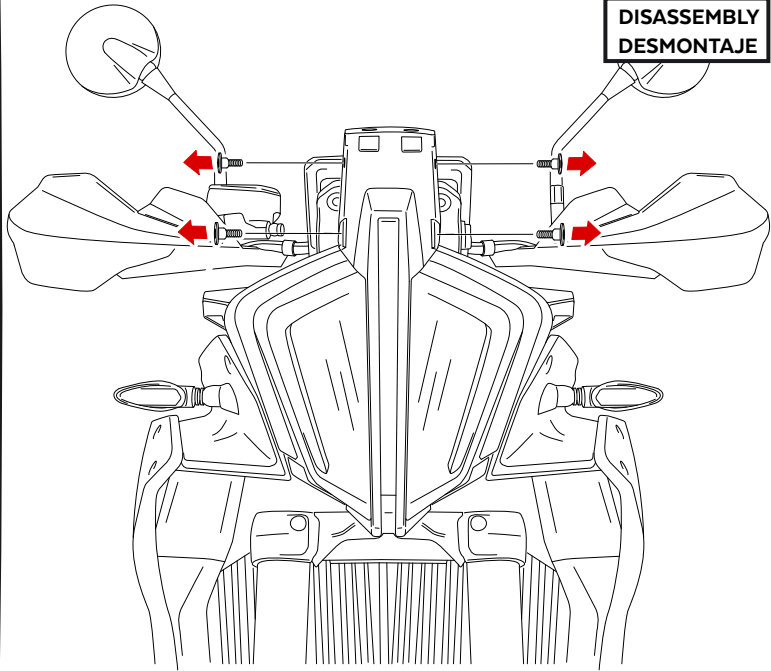

3

ASSEMBLY
MONTAJE

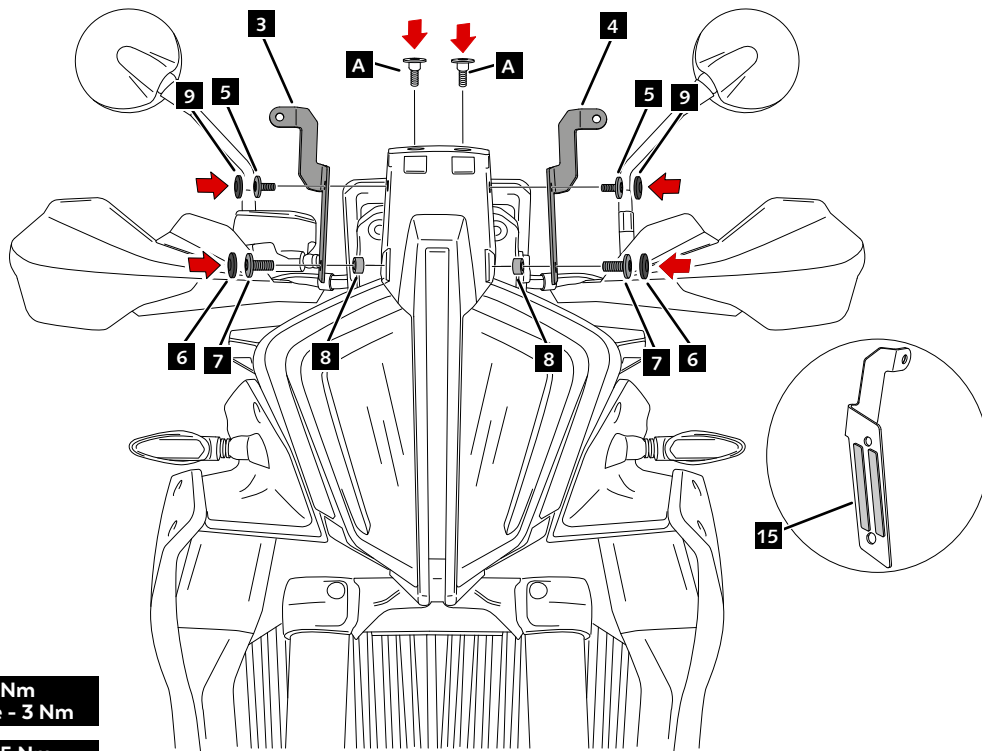

5 Par de apriete - 3 Nm
Tightening torque - 3 Nm

7 Par de apriete - 3.5 Nm
Tightening torque - 3.5 Nm

A Tornillería original
Original screws

KTM 890 SMT '23-

INSTRUCCIONES DE MONTAJE - MOUNTING INSTRUCTIONS - MONTAGEANLEITUNG

4

**DISASSEMBLY
DESMONTAJE**

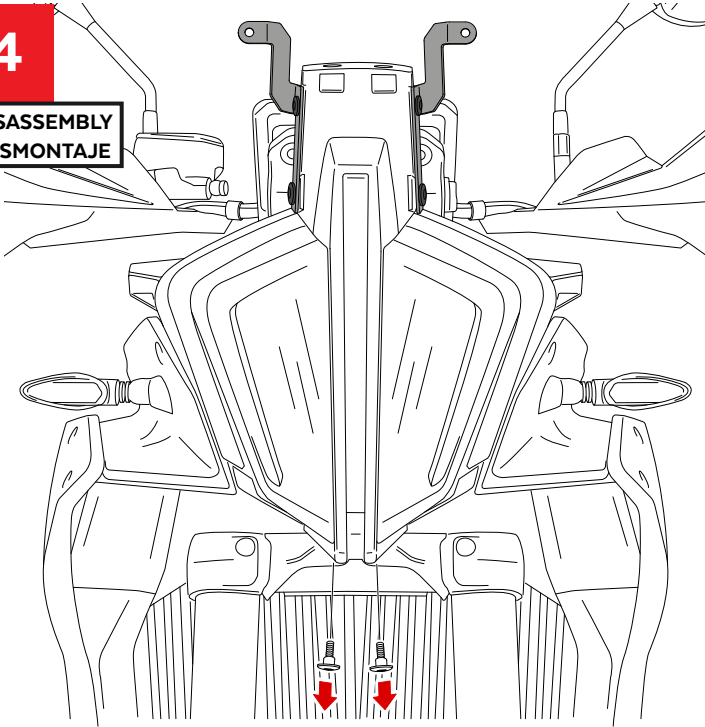

5

**ASSEMBLY
MONTAJE**

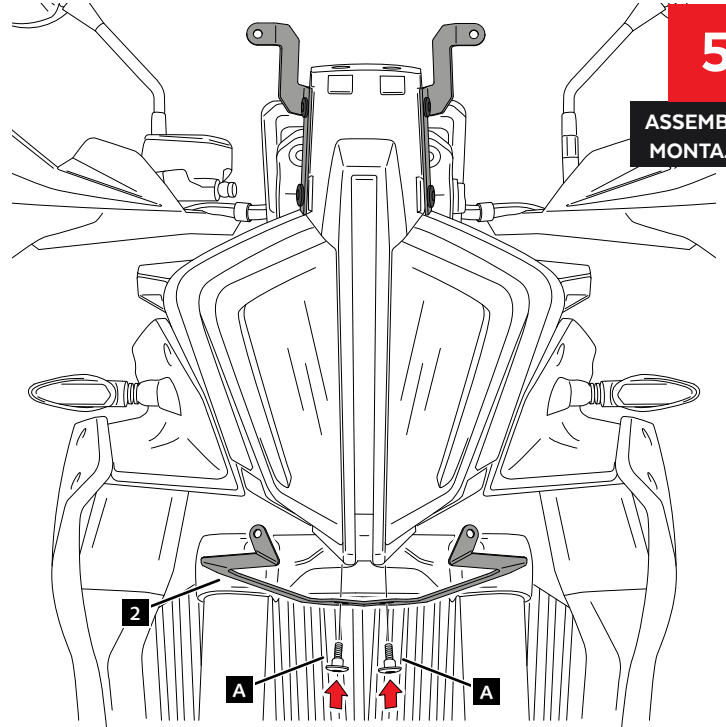

A Tornillería original
Original screws

A Par de apriete - 3.5 Nm
Tightening torque - 3.5 Nm

6

**ASSEMBLY
MONTAJE**

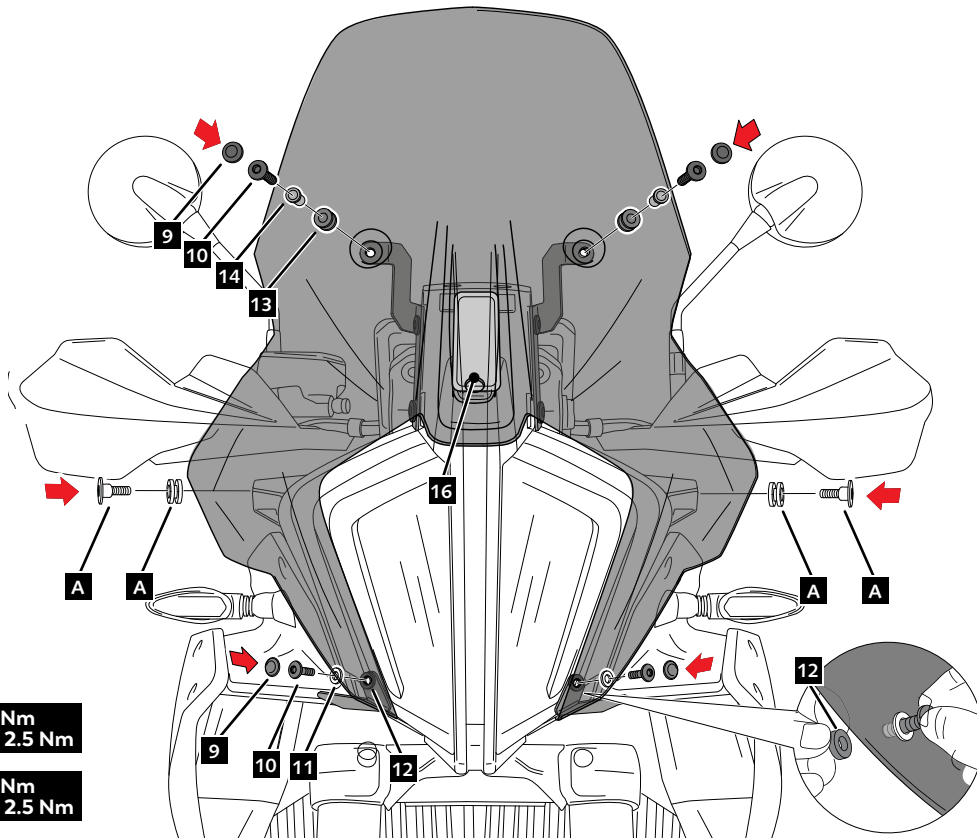

10 Par de apriete - 2.5 Nm
Tightening torque - 2.5 Nm

A Par de apriete - 2.5 Nm
Tightening torque - 2.5 Nm

A Tornillería original
Original screws

2.0 MULTI-ADJUSTABLE VISOR (FIX)

M O U N T I N G I N S T R U C T I O N S

REF 20763

UNIVERSAL (FIXED VERSION)



1 Person

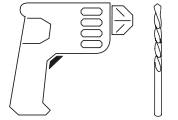

Ø7



15 min



PHILLIPS
SCREWDRIVER



EASY

ALLEN
Nº 4



ID	PIEZA/PART	DESCRIPCIÓN	DESCRIPTION	QTY	REF
1		Visera de policarbonato antirayadas	Antiscratch polycarbonate Visor	1	20765H/WM3
2		Plantilla	Template	1	PLANTILLA-VISOR
3		Mecanismo Izquierdo	Left Mechanism	1	See exploding page 2
4		Mecanismo Derecho	Right Mechanism	1	See exploding page 2

2.0 MULTI-ADJUSTABLE VISOR (FIX)

INSTRUCCIONES DE MONTAJE - MOUNTING INSTRUCTIONS - MONTAGEANLEITUNG

1

EXPLOTING

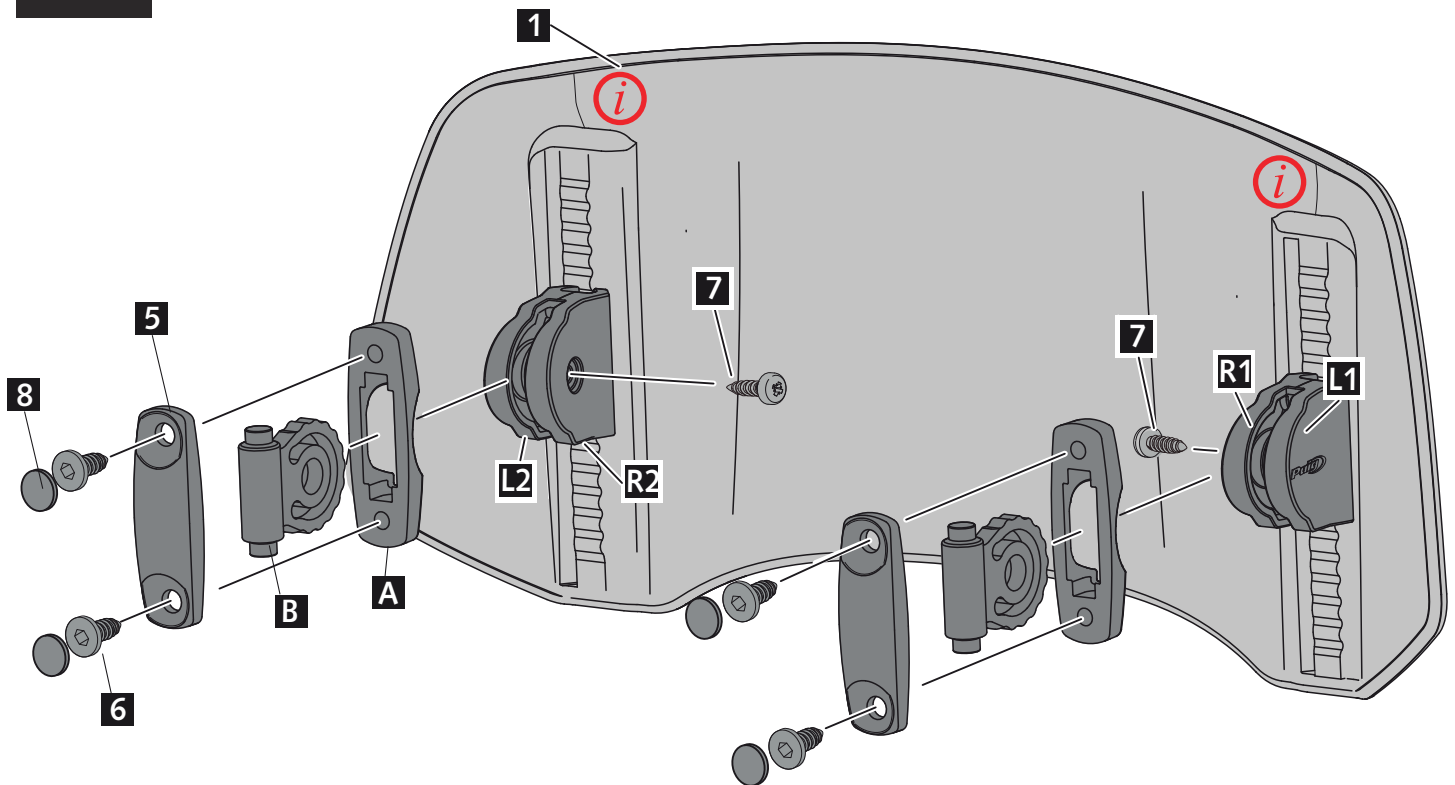

i LINEA DE PARTICIÓN DEL MOLDE DE INYECCIÓN. PARTING LINE OF THE INJECTION MOLD **i**

ID	PIEZA/PART	DESCRIPCIÓN	DESCRIPTION	QTY	REF
A		Tapa pieza eje	Axle part cover	2	TAPAEJE-VISOR--
B		Pieza eje	Axle part	2	EJE-FIX-VISOR--
L2		Tapa 2 Logo	Logo cover 2	1	TAPALAT-VISORL2
R2		Tapa 2 Tornillo	Screw cover 2	1	TAPALAT-VISORR2
L1		Tapa 1 Logo	Logo cover 1	1	TAPALAT-VISORL1
R1		Tapa 1 Tornillo	Screw cover 1	1	TAPALAT-VISORR1
5		Tapa cúpula	screen cover	2	TAPAFIX-VISOR--
6		Tornillo allen S.T. 6,3 x14	S.T. 6,3 x14 Allen screw	4	TOZN00M60000258
7		Tornillo Ø3,5x9,5 DIN7981 C (negro)	Ø3,5x9.5 DIN7981 C screw (black)	2	TORNI-D7981-907
8		Tapón tornillo M6	M6 Screw cap	4	TAPON-----81

2.0 MULTI-ADJUSTABLE VISOR (FIX)

INSTRUCCIONES DE MONTAJE - MOUNTING INSTRUCTIONS - MONTAGEANLEITUNG

2

ASSEMBLY
MONTAJE

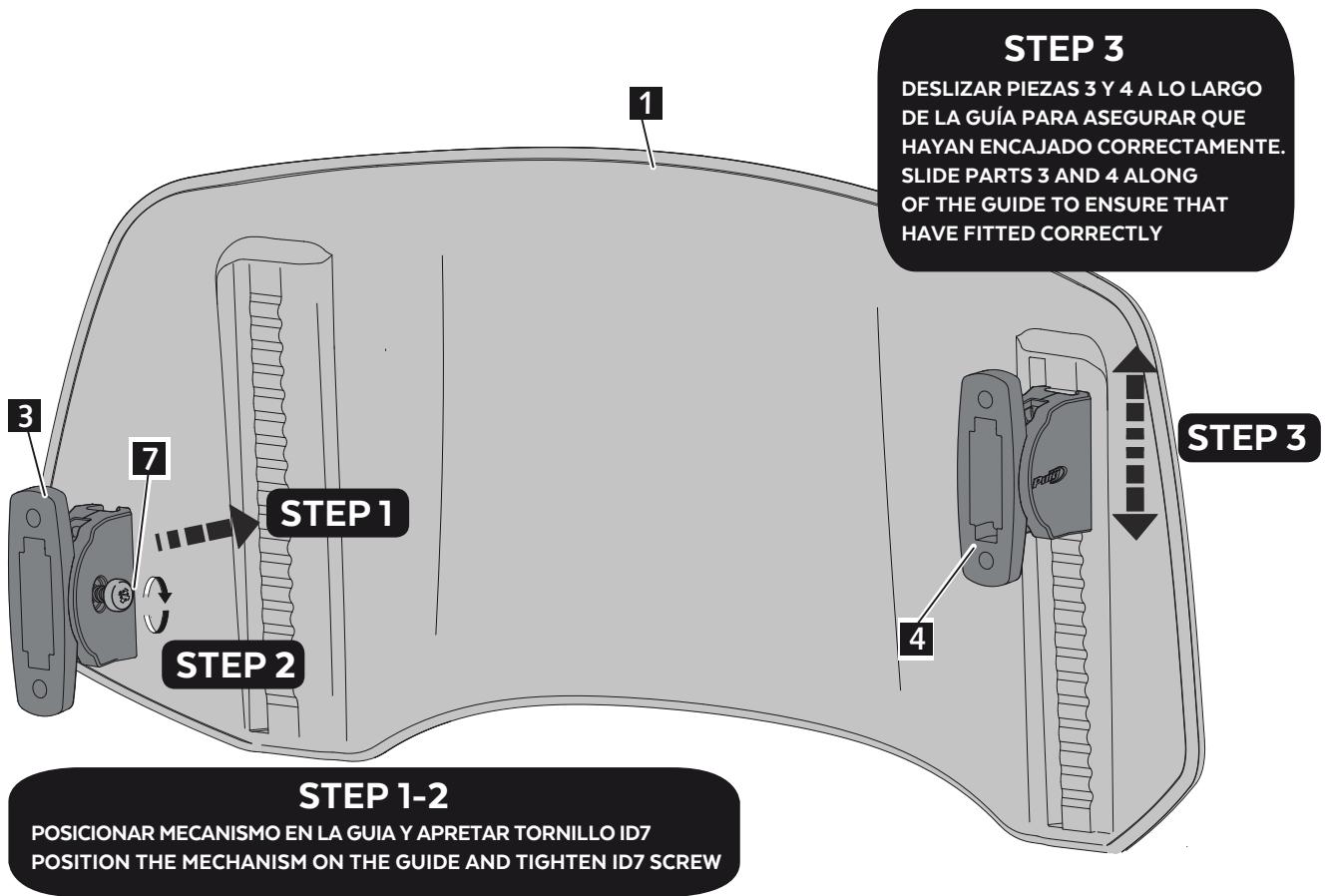

PAR APRIETE TORNILLO ID7 1 Nm
TIGHTENING TORQUE FOR ID7 SCREW 1 Nm

2.0 MULTI-ADJUSTABLE VISOR (FIX)

INSTRUCCIONES DE MONTAJE - MOUNTING INSTRUCTIONS - MONTAGEANLEITUNG

3

SCREEN TYPE “ ——— ”

ASSEMBLY
MONTAJE

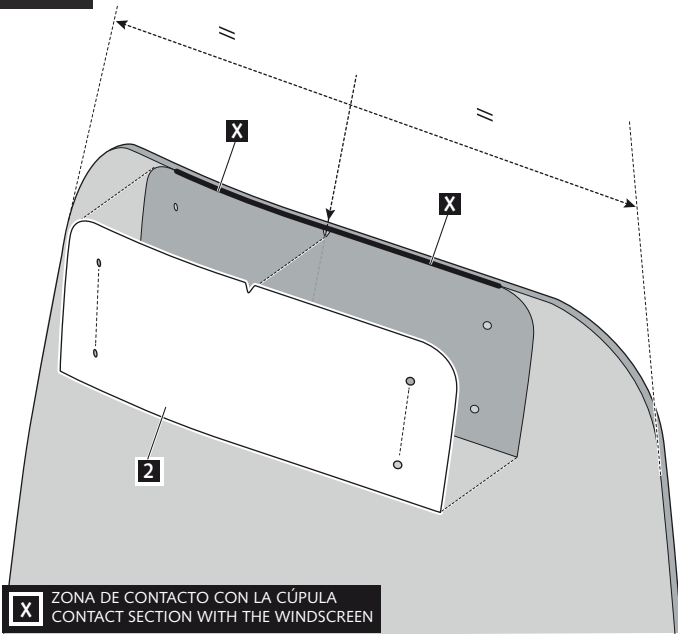

X ZONA DE CONTACTO CON LA CÚPULA
CONTACT SECTION WITH THE WINDSCREEN

SCREEN TYPE “ ——— ”

3

ASSEMBLY
MONTAJE

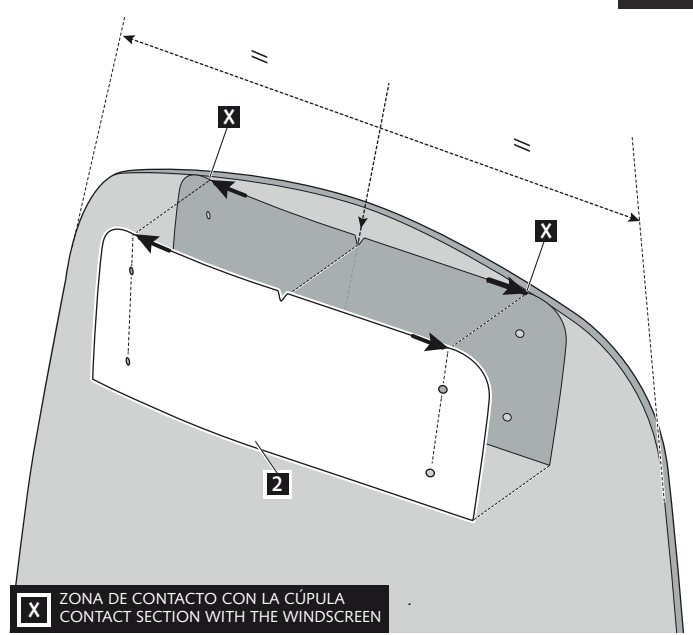

X ZONA DE CONTACTO CON LA CÚPULA
CONTACT SECTION WITH THE WINDSCREEN

3

SCREEN TYPE “ ——— ”

ASSEMBLY
MONTAJE

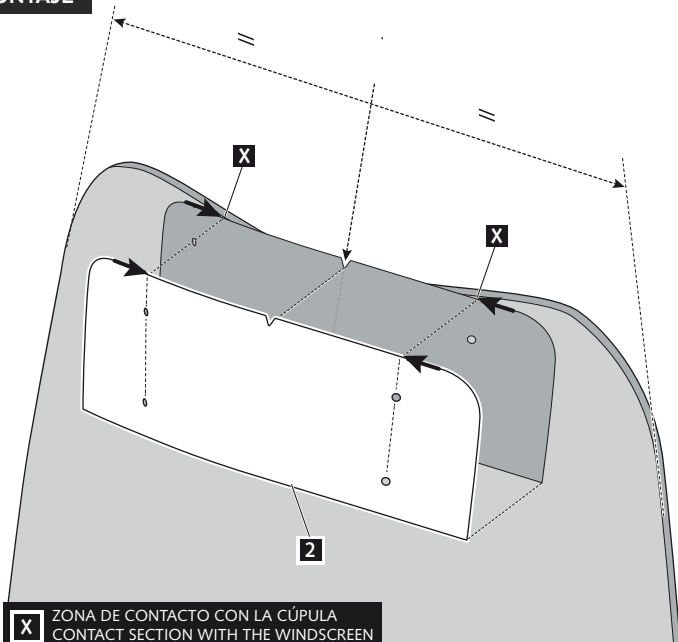

X ZONA DE CONTACTO CON LA CÚPULA
CONTACT SECTION WITH THE WINDSCREEN

4

ASSEMBLY
MONTAJE



UTILIZAR UN TACO DE MADERA EN LA POSTERIOR
USE A WOOD BLOCK ON THE OTHER SIDE

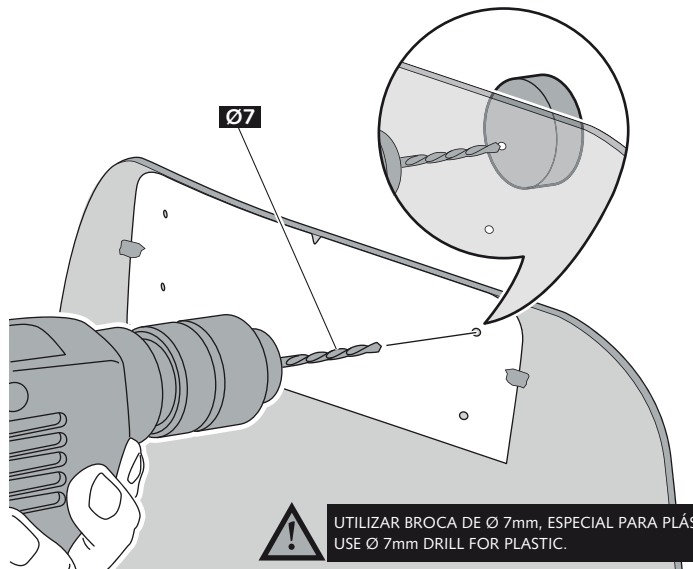

UTILIZAR BROCA DE Ø 7mm, ESPECIAL PARA PLÁSTICO.
USE Ø 7mm DRILL FOR PLASTIC.

2.0 MULTI-ADJUSTABLE VISOR (FIX)

INSTRUCCIONES DE MONTAJE - MOUNTING INSTRUCTIONS - MONTAGEANLEITUNG

5

ASSEMBLY
MONTAJE

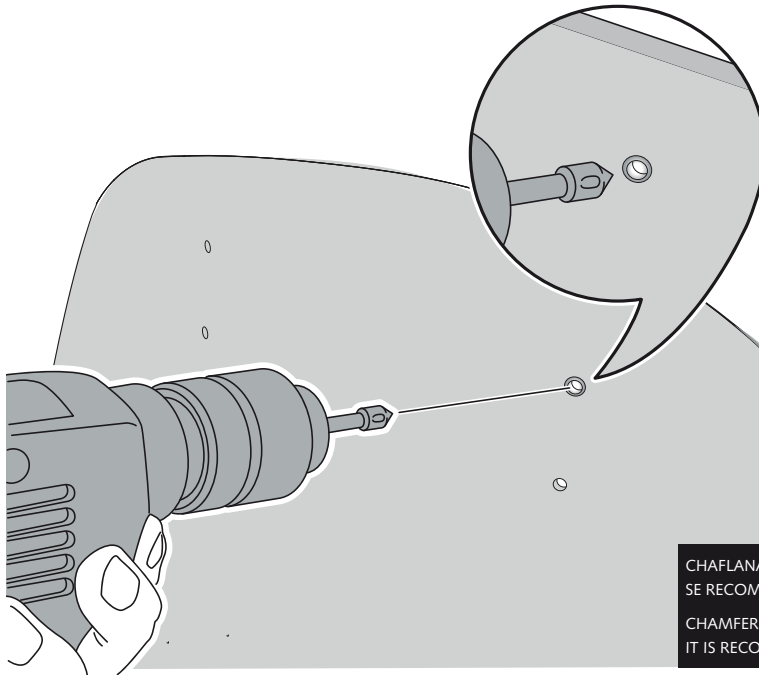

CHAFLANAR LOS 4 AGUJEROS POR AMBOS LADOS.
SE RECOMIENDA REALIZAR CHAFLAN $\varnothing 10\text{mm} - \varnothing 20\text{mm}$
CHAMFER THE FOUR HOLES ON BOTH SIDES.
IT IS RECOMMENDED TO MAKE CHAMFER $\varnothing 10\text{mm} - \varnothing 20\text{mm}$

6

ASSEMBLY
MONTAJE

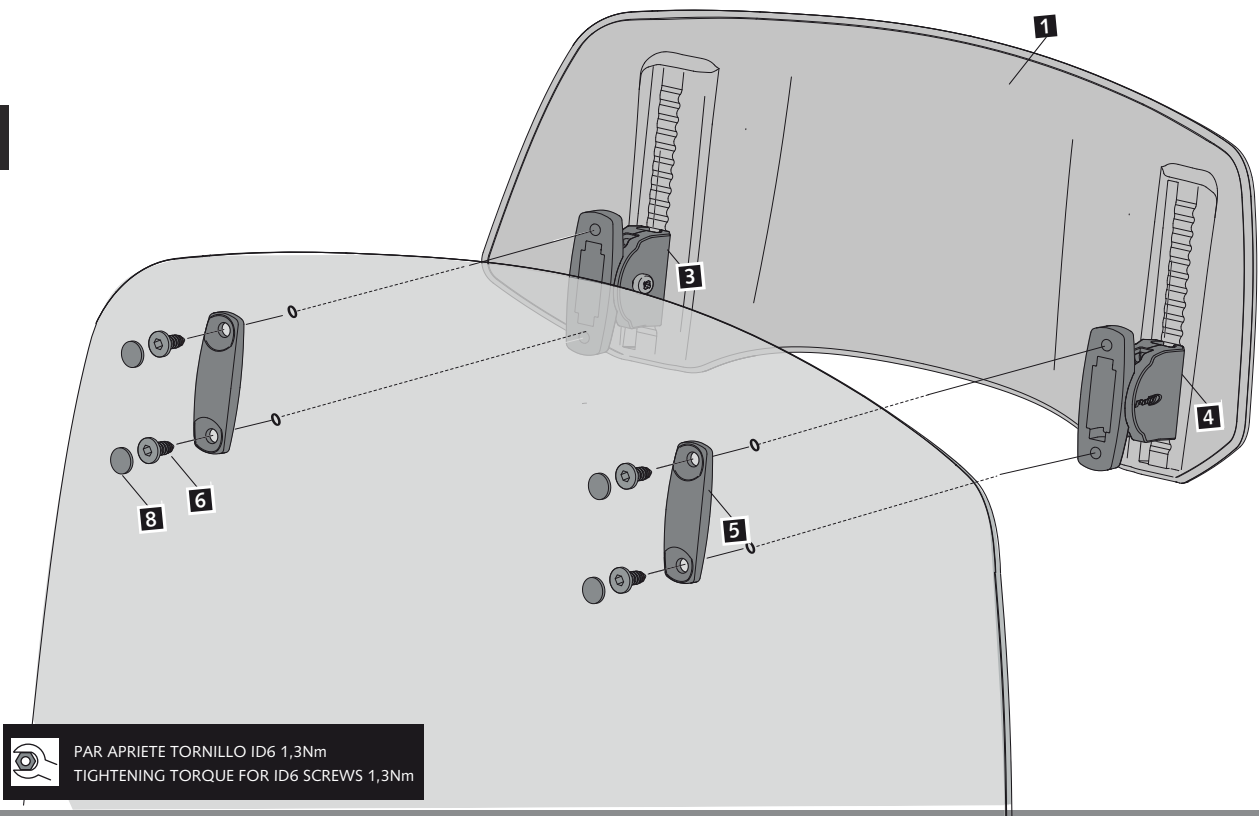

PAR APRIETE TORNILLO ID6 1,3Nm
TIGHTENING TORQUE FOR ID6 SCREWS 1,3Nm