

# BMW F750GS / F850GS / ADV '18-

## M O U N T I N G I N S T R U C T I O N S

REF 3691

GUARDABARROS MONOBRAZO / SINGLE SWING ARM FENDER



ID	PIEZA/PART	DESCRIPCIÓN	DESCRIPTION	QTY	REF
1		Guardabarros	Mudguard	1	10700JM3
2		Soporte guardabarros aluminio espesor 8mm ( Negro)	Mudguard aluminium support thickness 8mm ( Black)	1	SOPOR3P4-B-3691
3		Soporte metálico con regulación, espesor 3mm ( Negro)	Regulation metal support thickness 3mm ( Black)	1	SOPOR2P8-P10700
4		Soporte metálico, espesor 1,5mm ( Negro)	Metal support, thickness 1,5mm( Black)	1	SOPOR2P8-X10700
5		Soporte metálico brida 1 espesor 3mm ( Negro)	Flange 1 metal support thickness 3mm ( Black)	1	SOPOR3P4-S-3691
6		Soporte metalico brida 2 espesor 3mm ( Negro)	Flange 2 metal support thickness 3mm ( Black)	1	SOPOR3P4-I-3691
7		Arandela de goma Ø4,5x Ø11x 2 mm	Ø4,5x Ø11x 2 mm rubber washer	3	ARAND-EPDM--722
8		Tornillo Allen M8x25 DIN912	M8x25 DIN912 Allen screw	2	TORNI-D912--241
9		Tornillo Allen M6x20 DIN 912	M6x20 DIN 912 Allen screw	2	TORNI-AD912-489
10		Tornillo Allen M5x16 Ø11 ISO 7380	M5X16 Ø11 ISO 7380 Allen screw	3	TORNI-I7380-493
11		Arandela M5 nylon	M5 nylon washer	3	ARNV00000000245
12		Tapón M5 ISO 7380	M5 screw cap	3	TAPON-----85
13		Tuerca autoblocante met. M8 DIN6927	M8 lock nut DIN6927	4	TUERCAD6927-875
14		Tuerca autoblocante M6 DIN6927	M6 lock nut DIN6927	4	TUERCAD6927-876
15		Adhesivo protector	Protector adhesive	1	ADHESI-----269

\* Algunos de los Componentes se suministran montados / Some components are supplied assembled

# BMW F750GS / F850GS / ADV '18-

INSTRUCCIONES DE MONTAJE - MOUNTING INSTRUCTIONS - MONTAGEANLEITUNG

**1**

DISASSEMBLY  
DESMONTAJE

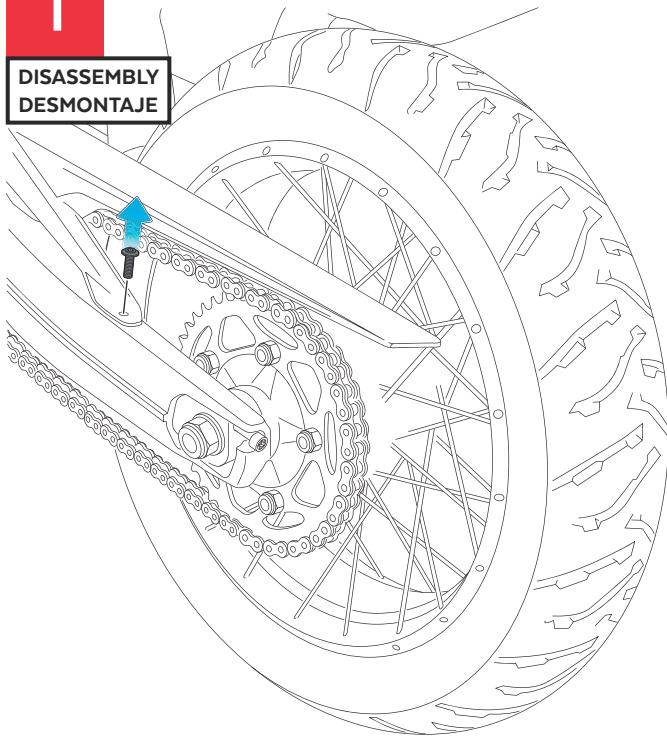

**2**

ASSEMBLY  
MONTAJE

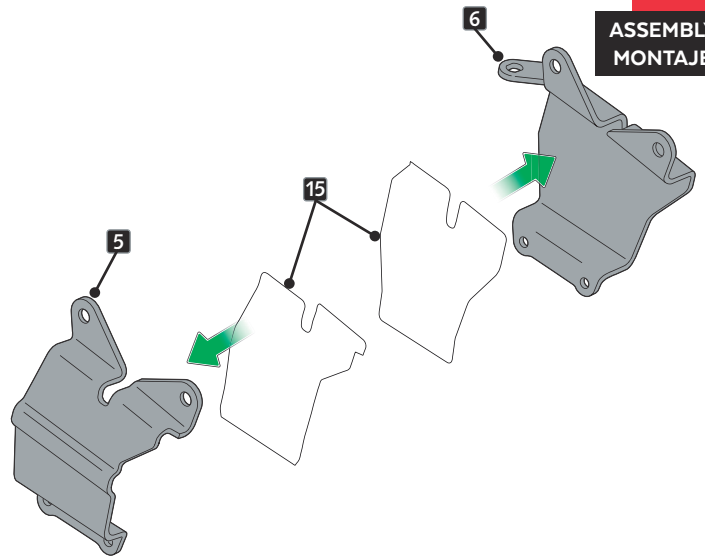

- COLOCAR LOS ADHESIVOS PROTECTORES EN LOS SOPORTES-BRIDAS.  
- PLACE PROTECTIVE ADHESIVE ON THE FLANGE SUPPORT.

**3**

ASSEMBLY  
MONTAJE

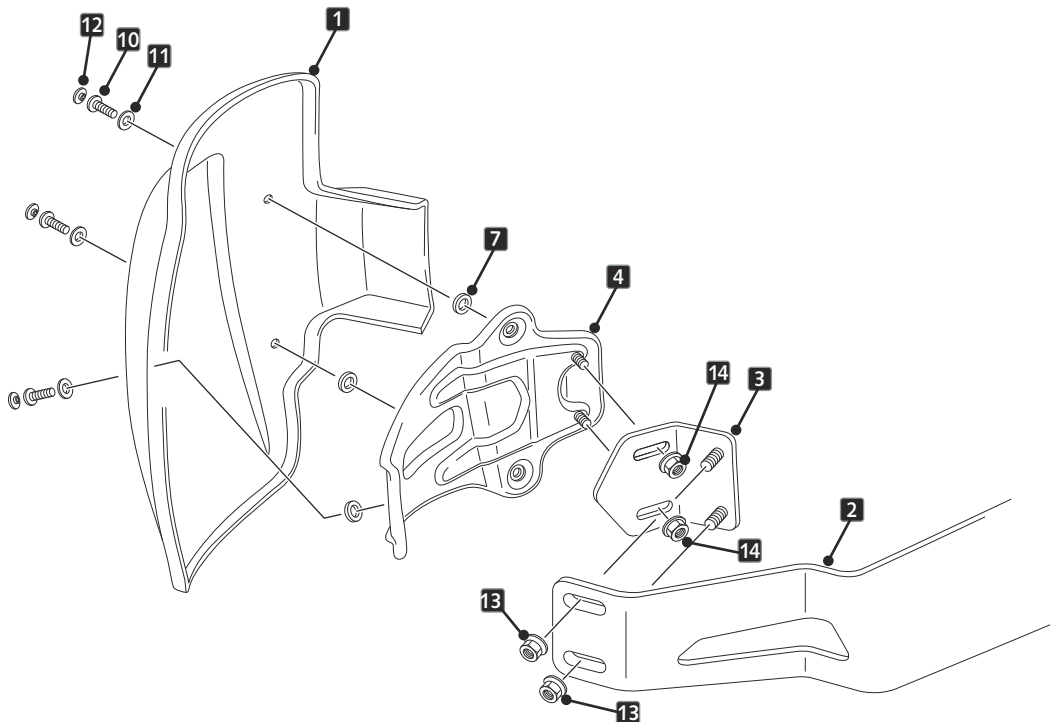

# BMW F750GS / F850GS / ADV '18-

INSTRUCCIONES DE MONTAJE - MOUNTING INSTRUCTIONS - MONTAGEANLEITUNG

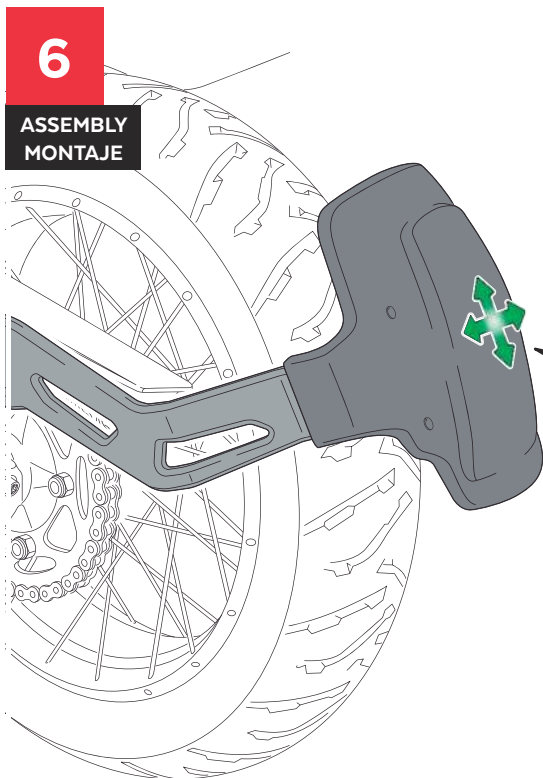
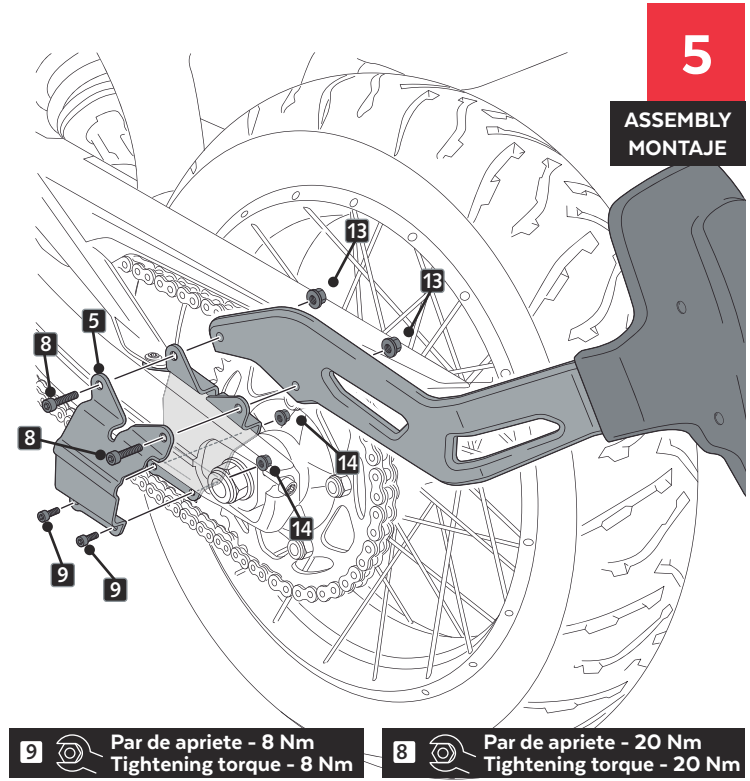
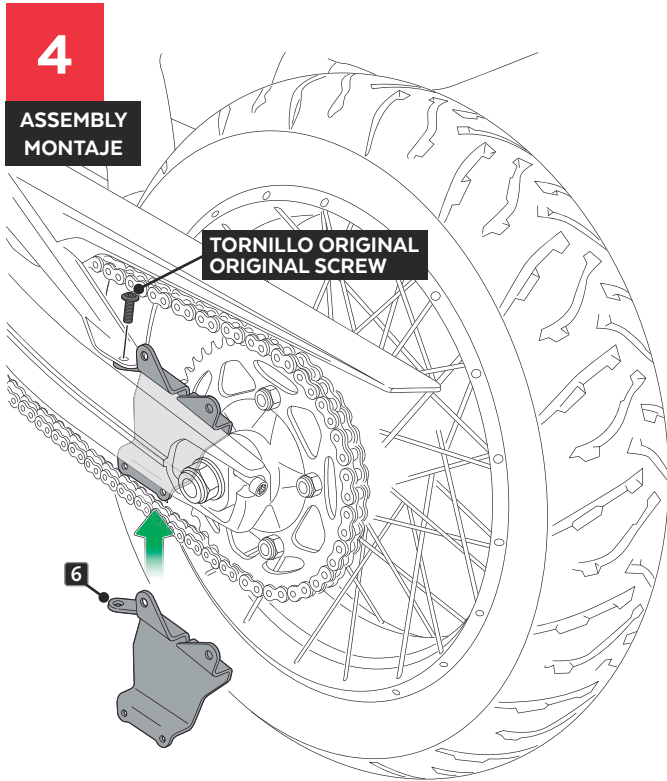

**!** SE RECOMIENDA REALIZAR EL REAPRIETE DE LA TORNILLERIA DESPUES DE REALIZAR 200 Km.  
IT IS RECOMMENDED TO CHECK TIGHTENING ALL THE BOLTS AFTER DRIVING 200 Km.

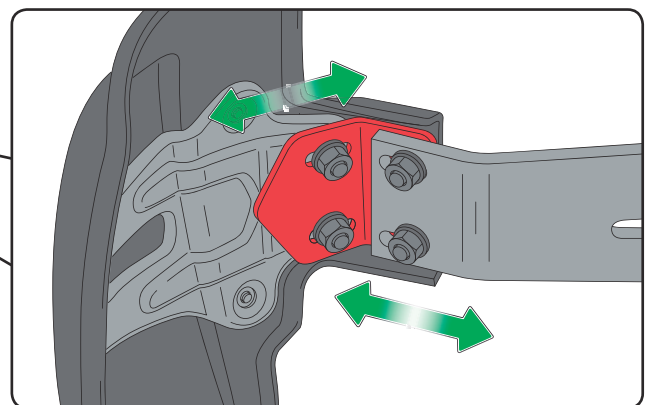

**!** AJUSTAR LA POSICIÓN Y APRETAR LAS TUERCAS.  
ADJUST POSITION AND TIGHTEN LOCK NUTS.